

640 MAINTENANCE INSTRUCTIONS

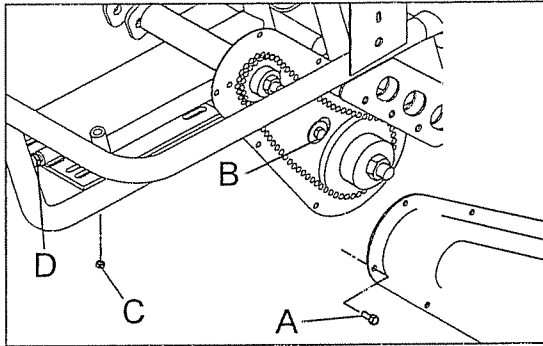

ENGINE CHAIN ADJUSTMENT INSTRUCTIONS

- 1) REMOVE CHAIN COVER BOLTS "A" WITH 3/8" NUT DRIVER OR SOCKET AND REMOVE COVER
- 2) LOOSEN BOLT "B" WITH 1/2" SOCKET AND WRENCH. DO NOT REMOVE
- 3) LOOSEN (4) ENGINE MOUNT NUTS "C" WITH 1/2" SOCKET. DO NOT REMOVE
- 4) TIGHTEN BOLT "D" WITH 9/16" SOCKET UNTIL CHAIN HAS APPROXIMATELY 1/4-3/8" OF SLACK
- 5) RETIGHTEN AND ASSEMBLE IN REVERSE ORDER

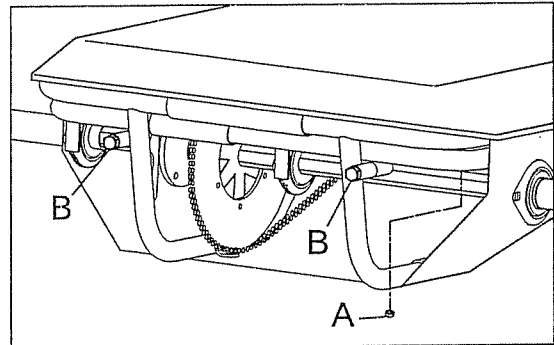

AXLE CHAIN ADJUSTMENT INSTRUCTIONS

- 1) LOOSEN (4) SWINGARM SLIDE BOLTS "A" WITH 9/16" SOCKET AND WRENCH. DO NOT REMOVE
- 2) TIGHTEN BOLTS "B" EVENLY IN AN ALTERNATING FASHION UNTIL CHAIN HAS APPROXIMATELY 1/4-3/8" OF SLACK
- 3) RETIGHTEN BOLTS "A"

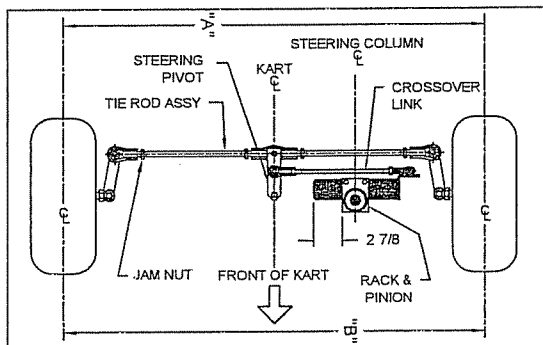

STEERING ALIGNMENT INSTRUCTIONS

- 1) LOOSEN ALL TIE ROD NUTS
- 2) ROTATE STEERING WHEEL SUCH THAT DIMENSION FROM THE END OF THE RACK AND PINION TO THE RACK AND PINION BODY IS 2 7/8". REF ABOVE DIAGRAM
- 3) ADJUST THE CROSSOVER LINK SUCH THAT THE STEERING PIVOT RUNS PARALLEL TO THE CENTERLINE OF THE KART AS SHOWN
- 4) TIGHTEN CROSS OVER LINK JAM NUTS
- 5) ADJUST RH AND LH TIE ROD ASSEMBLIES SUCH THAT DIMENSION "A" IS 3/8"-1/2" LONGER THAN DIMENSION "B"
- 6) RETIGHTEN RH AND LH TIE ROD JAM NUTS

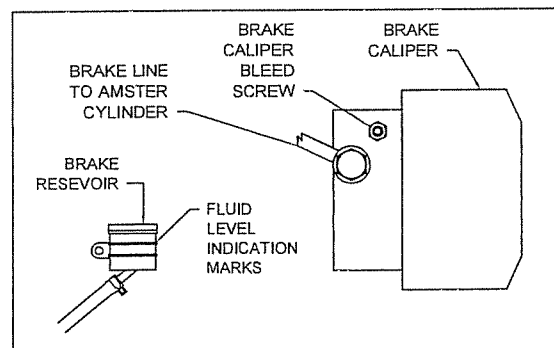

BRAKE BLEED/ADJUSTMENT INSTRUCTIONS

- 1) INSPECT FLUID RESEVOIR BEHIND SEAT ENSURE THAT THE FLUID LEVEL IS BETWEEN THE INDICATION MARKS
- 2) ADD DOT 3 BRAKE FLUID IF REQUIRED
- 3) UNCAP AND LOOSEN BRAKE CALIPER BLEED SCREW
- 4) HAVE A SECOND PERSON DEPRESS THE BRAKE PEDAL SLOWLY UNTIL THE PEDAL BOTTOMS OUT
- 5) HOLD THE PEDAL IN THE DEPRESSED POSITION UNTIL THE BLEED SCREW IS RETIGHTENED
- 6) PUMP THE BRAKE PEDAL TWO TO THREE TIMES AND REPEAT PROCEDURE UNTIL THE PEDAL FEELS FIRM DURING THE PEDAL STROKE
- 7) AIR BUBBLES SHOULD BE SEEN AT THE BLEED SCREW DURING THE BLEED PROCEDURE UNTIL PEDAL BECOMES FIRM
- 8) TIGHTEN AND RECAP THE BLEED SCREW